

Revision	Note	Appr. Date	Appr. By
A			

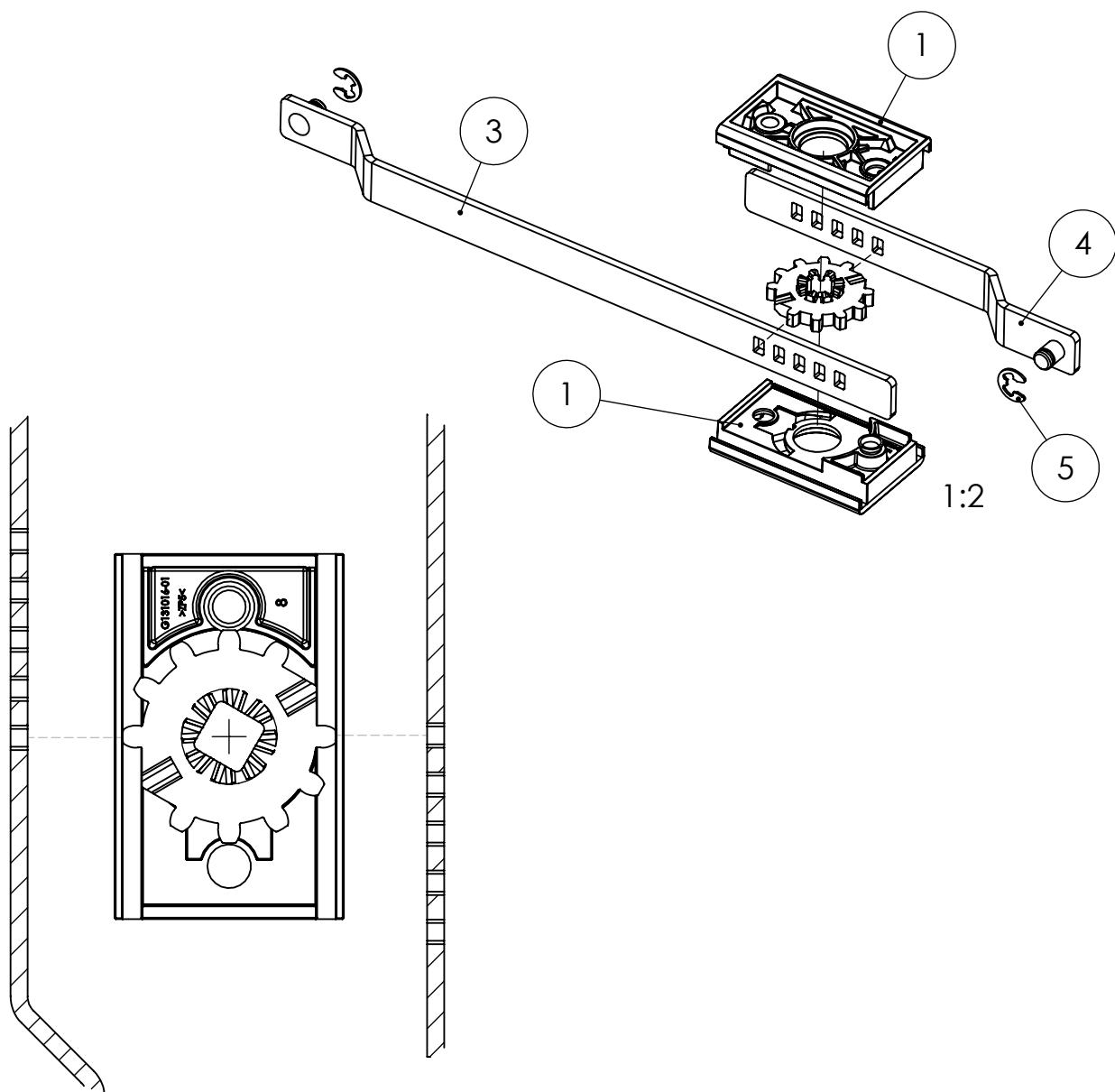

Pos. 5 is packed separately.

CAD-model: 00072529, applies unless otherwise stated.

Pos	Qty	Article No.	Description	Material	Surface Treatment
1	2	131116-01	Housing for control mechanism	Zinc	Zn-plated 10-15µm
2	1	139016-02	Gear for control mechanism	Sint-C40, DIN30910	Untreated
3	1	131116-03	Rod L=225mm		
4	1	131116-04	Rod L=125mm		
5	2	062190	E-clip RSM 5 Steel FZB	Steel	Zn-plated 10-15µm

Design	Date	Scale	Weight	Material (se)	Material (int'l)	Surface treatment
DJ	2017-06-21	1:1	203.33g			
SPANJOLETT Ståndrev Control mechanism						Tolerances unless otherwise specified SS-ISO 2768-c
Industrilas http://www.industrilas.com +46 (0)10-130 75 00				Project article No.	Article No.	View orientation
					8-2705-28	
						Approved by DJ
						Approved date 2017-06-21
						Revision A

2019-09-06 12:36:32

Dok. nr. 4.5-A4

Revision	Note	Appr. Date	Appr. By
A			

Closed position

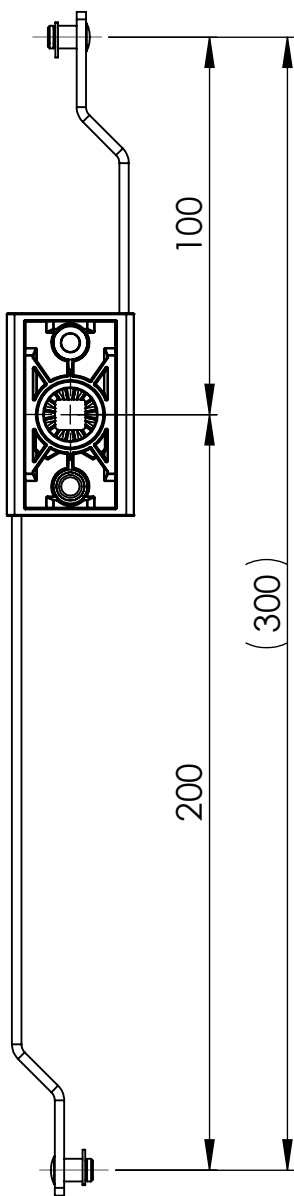

Opened position

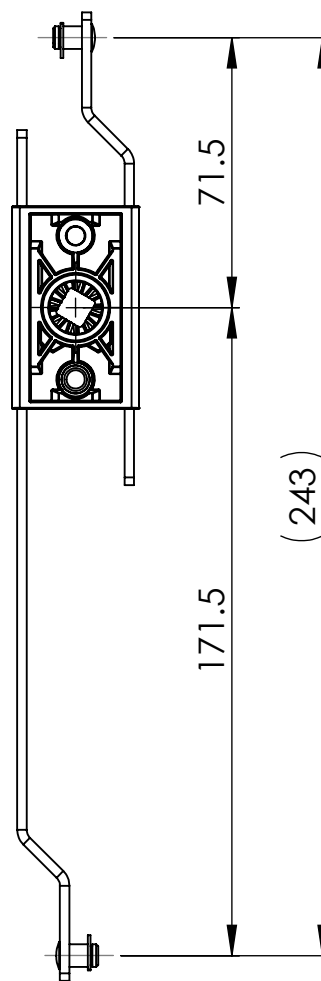

CAD-model: 00072529, applies unless otherwise stated.

Design	Date	Scale	Weight	Material (se)	Material (int'l)	Surface treatment
DJ	2017-06-21	1:2	203.33g			
SPANJOLETT Ståndrev Control mechanism						Tolerances unless otherwise specified SS-ISO 2768-c
Industrilas http://www.industrilas.com +46 (0)10-130 75 00						View orientation
Project article No.				Approved by		Approved date
				DJ		2017-06-21
Article No.						Revision
8-2705-28						A

2019-09-06 12:36:32

Dok. nr. 4.5-A4